

# montano VKT



## DEALER MANUAL **MAX Drive System**



## Main technical parameters

Voltage (DCV)	36
Rated power (W)	250
Nominal efficiency (%)	≥ 80%
Nominal rotation speed	100± 5
Maximum torque (Nm)	≥80
Crankset	38T
Weight (kg)	3.9
Sensors	Assisted pedalling speed sensor, torque sensor and speed sensor in the wheel and temperature sensor
Noise level (dB)	< 55
Operating temperature range	-20°C~55°C
Water resistance level	IP66
Certifications	CE ROHS / EN14766 / EN14764 / REACH

# DISPLAY

## Display specifications and parameters

- Voltage: 36 V
- Rated current: 10 mA
- Maximum continuous current: 30 mA
- Leakage current with power off: <1 uA
- Direct current supplied by the control unit: 50 mA
- Operating temperature: -18 ~ 60%
- Storage temperature: -30 ~ 70%
- Water resistance level: IP65
- Storage humidity: 30% – 70%

## Appearance and dimensions



For the C171 display settings, use the dealer's Best Software.

## Overview of features and key definitions

### Overview of features

- Uses a bidirectional serial communication protocol, simple operations on the display via the 5-key keypad.
- Speedometer display: real time speed (SPEED), maximum speed travelled (MAXS) and average speed (AVG)
- km or miles: the user can choose between km and miles
- Intelligent battery level indicator: thanks to an optimisation algorithm, the battery level display remains stable and the problem of the fluctuating indicator encountered with other displays is solved
- Automatic lighting: the rear light, front light and display turn on/off automatically based on the lighting conditions.
- 5 backlight levels
- 5 assist levels: level can be set from 1 to 5
- Distance travelled indicator: the maximum distance that can be displayed is 99999. The user can view the distance for the single trip (TRIP) or the total distance (TOTAL)
- Error message display
- Assisted start
- Settings: various parameters such as mode, wheel diameter, speed limit
- Maintenance alerts: (this feature can be deactivated) the maintenance alert feature is displayed based on the battery charge cycles and the distance travelled. The display automatically calculates the lifespan of the battery and alerts the user when the number of cycles surpasses the set value. An alert is also displayed when the total distance travelled exceeds the set value.

### About the display

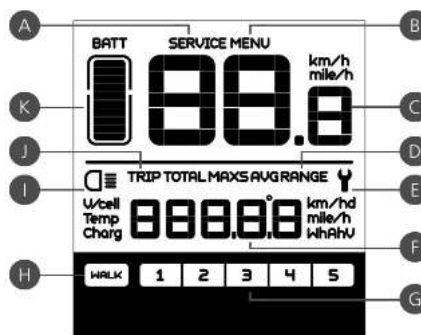

- A Maintenance alert: when maintenance is needed, this symbol is displayed: **SERVICE** (the distance travelled or the number of battery charge cycles has exceeded the set value – this feature can be deactivated)
- B Menu
- C Speedometer display: speed, km/h, and miles/h
- D Speed mode: average speed (AVG km/h), maximum speed reached (MAXS km/h)
- E Error messages: when an error is detected, this symbol is displayed
- F Distance indicator: distance displayed based on the settings.
- G Level indicator: the selected level (between 1 and 5) is displayed. No numerical display means that the motor is currently providing no assistance. If the user is on foot and is pushing the e-bike, the following symbol is displayed:
- H Assisted start
- I Light indicator: displayed only if the lights or backlight are turned on

- J Distance mode: the single trip distance (TRIP) or total distance (TOTAL) is displayed
- K Battery level: battery indicator with 10 segments

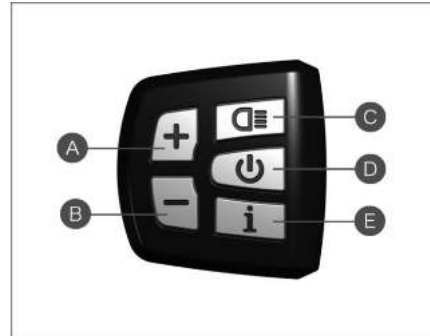

### Key definitions





- A up
- B down
- C lights
- D on/off
- E mode

## Standard operations

### ON/OFF SWITCH

Turn the device on. Press and hold  for 2 seconds to turn on the display. Press and hold  for 2 seconds a second time to turn off the display. If the bicycle is not used, the display will switch off automatically after 5 minutes (this time limit can be adjusted).

### SELECTING THE ASSIST MODE

In manual adjustment mode, press  or  to choose the desired motor assist level. The lowest level is 1 and the maximum level is 5. When the display turns on, the default level is 1. No numerical display means that there is currently no assistance.

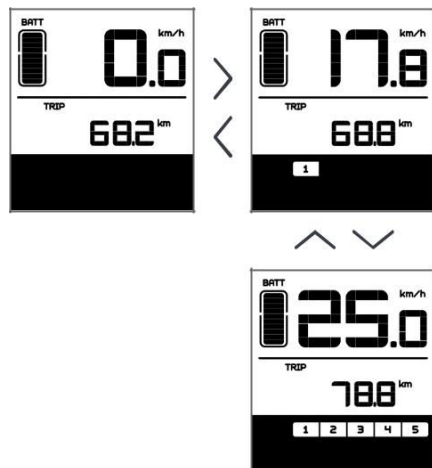

Selecting the motor assist level

### SWITCHING FROM DISTANCE MODE TO SPEED MODE

Tap **i** to switch between distance and speed.

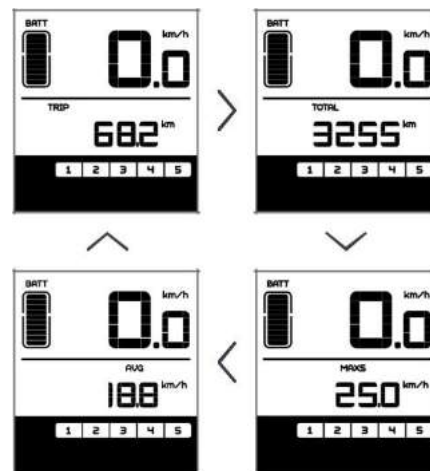

Single trip distance (TRIP/km) → Total distance (TOTAL/km) → Maximum speed (MAXS km/h)  
Average speed (AVG km/h)

They are displayed consecutively.



Switching between displays

#### LIGHT AND DISPLAY BACKLIGHT SWITCH

Press  for 2 seconds and the display backlight and lights will be turned on. Press  for 2 seconds for a second time to turn them off. If the display is turned on in a dark place, the backlight and lights will turn on automatically. If the backlight and the lights are turned off manually, they must be switched on manually the next time they are needed.

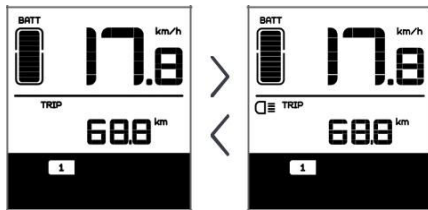

There are 5 levels of backlight brightness; these can be selected by the user.

#### ASSISTED START

Press  for 2 seconds. The bicycle will enter assisted start mode and the WALK symbol will be displayed.

Once you release the  key, you will exit assisted start mode.

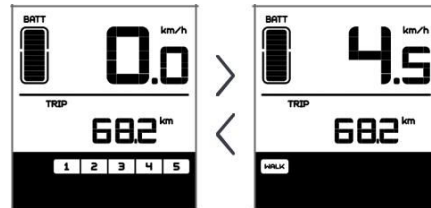

Switching from motor assist to assisted start

## BATTERY STATUS INDICATOR

When the battery status is normal, a certain number of segments are displayed on the LCD within the outline of a battery according to the current charge level.

If all 10 segments have disappeared and the outline is flashing, the battery needs to be charged as soon as possible.

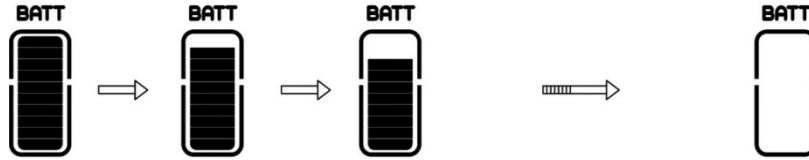

Number of segments	Charge percentage	Number of segments	Charge percentage	Number of segments	Charge percentage
10	$\geq 90\%$	6	$50\% \leq C < 60\%$	2	$15\% \leq C < 25\%$
9	$80\% \leq C < 90\%$	5	$45\% \leq C < 50\%$	1	$5\% \leq C < 15\%$
8	$70\% \leq C < 80\%$	4	$35\% \leq C < 45\%$	outline flashing	$C < 5\%$
7	$60\% \leq C < 70\%$	3	$25\% \leq C < 35\%$		

## Configuring the parameters

Items to be configured

- 1 > Data recovery
- 2 > km/miles
- 3 > Light sensitivity
- 4 > Display backlight brightness
- 5 > Automatic shutdown time
- 6 > Maintenance alert settings
- 7 > Password entry
- 8 > Wheel diameter selection
- 9 > Speed limit setting



### ENTERING SETTINGS MODE

When the display is active, press **i** twice (with a gap of less than 3 seconds). The system will enter the parameter settings menu. Press **i** twice again (with a gap of less than 3 seconds) to return to the main menu.

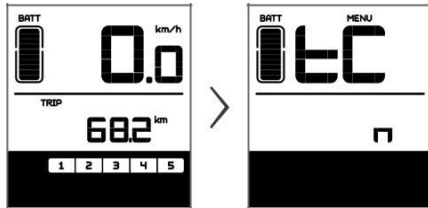

Menu to access the parameter settings

In Settings mode, when the parameter that you wish to change is flashing, press the **+** / **-** keys to adjust the value.

Tap **i** to switch between the parameters that you wish to set.

Press **i** twice (with a gap of less than 3 seconds) to exit the menu.

If no operation is performed for 10 seconds, the display will return to normal.

### DATA RECOVERY

Press **i** twice (with a gap of less than 3 seconds) to access the menu. "tC" is displayed. If you press **+**, a "Y" will also be displayed. The temporary data (maximum speed, average speed, km per trip) can now be deleted.

Press **i** briefly (for less than 3 seconds) to enter the km/mile settings interface.

If the user does not reset the data, the distance for each trip and the total usage time will be automatically deleted when the total usage time goes beyond 99 hours and 59 minutes.

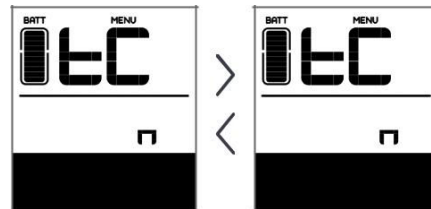

The data cannot be deleted when the light sensitivity function is set to 0 or when it is turned off.

### KM/MILES

When "S7" is displayed, press **+** or **-** to switch between km/h and miles/h or to set km or miles.

Once you are happy with this setting, press **i** briefly (for less than 3 seconds) to enter the light sensitivity settings interface.

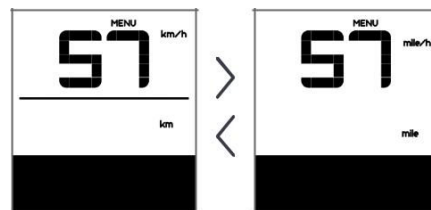

### LIGHT SENSITIVITY

When "bL0" is displayed, use **+** / **-** to choose the level (from 0 to 5). The higher the number, the more light-sensitive the display will be. Once you are happy with this setting, press **i** briefly (for less than 3 seconds) to enter the display backlight brightness interface.

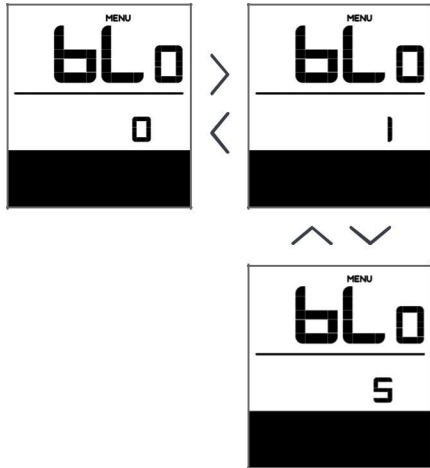

### DISPLAY BACKLIGHT BRIGHTNESS

When "bL1" is displayed, press **+** / **-** to choose the level (from 1 to 5). 1 is the lowest brightness setting, while 5 is the highest. Once you are happy with this setting, press **i** briefly (for less than 3 seconds) to enter the automatic shutdown settings interface.

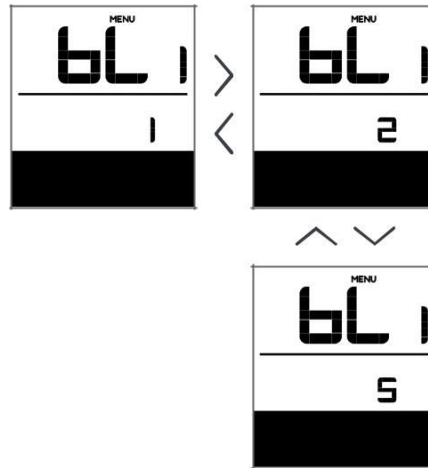

#### AUTOMATIC SHUTDOWN TIME

When "OFF" is displayed, press **+** / **-** to choose the level (from 1 to 9). The figure shows the number of minutes for which the display will remain active before automatically shutting down. Once you are happy with this setting, press **i** briefly (for less than 3 seconds) to enter the maintenance alert settings interface.

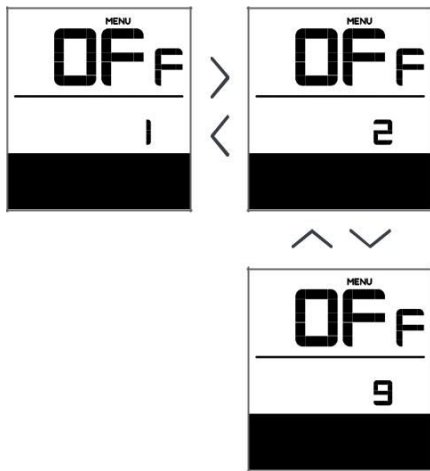

#### MAINTENANCE ALERTS (can be deactivated)

When "nnA" is displayed, press **+** / **-** to choose 0 or 1. 0 deactivates the feature, while 1 enables it. Once you are happy with this setting, press **i** briefly (for less than 3 seconds) to enter the password entry interface.

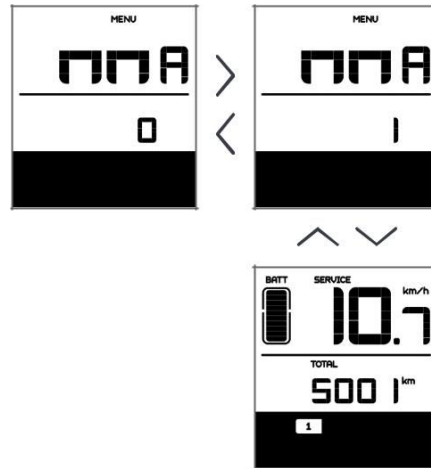

#### Maintenance alert settings

The display will ask you to carry out maintenance based on information such as the distance travelled and the number of battery charge cycles.

- When the total distance travelled exceeds 5,000 km (can be customised by the manufacturer), the display will show the symbol **SERVICE**  
When the display is turned on, the indicator showing the total accumulated distance will flash for 4 seconds, indicating that maintenance is required.
- When the number of battery charge cycles exceeds 100 (can be customised by the manufacturer), the display will show the symbol **SERVICE**  
When the display is turned on, the battery symbol will flash for 4 seconds, indicating that maintenance is required.
- The maintenance warning feature can be disabled:  
settings → maintenance warning (MA) → maintenance warning (MA) → 0

## ERROR CODE DEFINITIONS

The MAX-C966 display can highlight any malfunctions affecting your e-bike. When a malfunction is detected, this icon  is displayed.

One of the following error codes will be displayed in the Speed field.

Error code	Error description	Possible solution
"06"	Low voltage protection	Check the battery voltage
"07"	Overvoltage protection	Check the battery voltage
"08"	Cable malfunction inside the motor	Check the motor module
"09"	Phase cable malfunction in the motor	Check the motor module
"10"	The motor temperature has reached the limit	Stop the bicycle until error 10 disappears from the screen
"11"	Temperature sensor malfunction in the controller	Check the control unit
"12"	Current sensor malfunction	Check the control unit
"13"	Battery temperature malfunction	Check the battery
"21"	Battery sensor malfunction	Check the installation position of the speed sensor
"22"	BMS communication malfunction	Replace the battery
"30"	Communication failure	Check the control unit connection

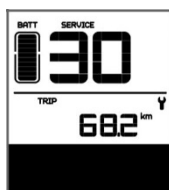

An error appearing on the display

NOTE: error code 10 is likely to appear on the display when the bicycle is ridden uphill for long periods of time. This indicates that the motor temperature has reached the safety limit. The user must therefore stop the e-bike and allow it to rest. If the user continues to use the e-bike, the motor will automatically shut off the power supply.

# HOUSING FOR RACK-MOUNTED BATTERY

The housing for the flat rack-mounted battery and the control unit box are supplied along with the luggage rack. The connection cables for the control unit are already assembled in the battery housing.

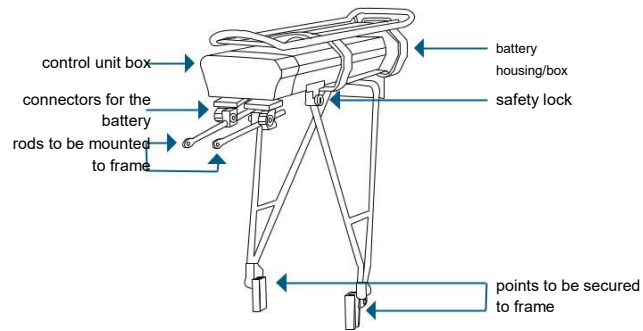

## USING THE BATTERY AND CHARGER

Fully charge the battery before using it for the first time!!!

The battery can be charged while mounted to the bike, or separately. The lock is used to fix the battery to the bicycle in the correct position.

If it is not fixed in place, it could be damaged and/or stolen. Turn the lock to remove the battery.

To remove the down tube battery, turn the lock clockwise (1)

and push the battery out of its housing while keeping the lock turned (2).

When the battery is mounted on the bike and inserted in the support case, it is automatically locked in place, so it is not necessary to turn the safety lock!

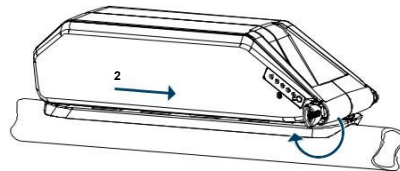

To recharge the battery, open the cap (3) covering the socket (4) and connect the charger (5).

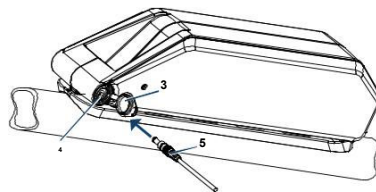

To remove the rack-mounted battery, first open the lock by turning it anti-clockwise (1), then push the battery out of its casing/housing. Once you have placed the battery back in its case, turn the safety lock clockwise to lock it in place and prevent it from falling out or being stolen.

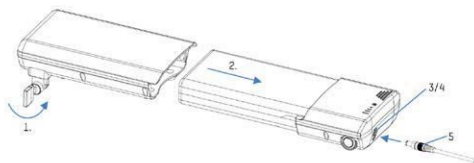

To charge the battery, open the cap (3) on the socket (4) and connect the charger (5).

After connecting the charger to the battery, connect the charger to the electrical outlet. The charger LED flashes red while the battery is charging; once it is charged, the LED turns

green.

A flashing LED on the battery's capacity indicator also indicates that charging is taking place.

(only on the down tube battery).

**Temperature:** from 0°C to 45°C  
Approx. 5/7

**Charging time:** hours (depending on the battery's capacity)

**Storage temperature:** from 5°C to 25°C (recommended)

**Storage temperature:** -20°C to 45°C (max. limits)

We recommend that you recharge the battery after each use. If you are not planning to use the battery for a long period of time (e.g. during winter), charge it completely before storing it. To avoid damage to the battery, recharge it every 12 weeks. Store it in a dry place and observe the temperatures indicated above.



Avoid direct sunlight and excessive temperatures



Keep the battery away from fire



CE mark (conformity): this battery is built in line with European standards



The cells contain lithium



Do not dispose of as household waste. Dispose of at an authorised waste collection point

- Use only original Ansmann chargers to charge the battery
- Avoid short circuits

- While charging, place the battery on an inflammable and heat-resistant surface. There should be no flammable or combustible objects nearby
- Never leave the battery unattended while charging
- Batteries are not a toy - Keep out of reach of children!
- The original Ansmann cables and sockets must not be cut or modified under any circumstances!



Improper use may lead to explosion, overheating or fire. Using this product incorrectly and failing to follow the instructions provided in this manual may result in defects or premature wear. Keep the instruction manual in a safe place and always hand it over along with the battery.

After charging the battery, unplug the charger from the electrical outlet and disconnect it from the battery.

Close the battery socket cap to prevent water from entering and avoid corrosion.

The battery has a capacity indicator to allow you to check the charge level. Tap the button on the capacity indicator. The charge level is briefly displayed by means of LEDs that illuminate. While riding, you can check the battery charge level on the handlebar display (the devices need to be calibrated, so the charge shown on the display may be different from the level displayed by the battery indicator).

Once the battery is fully charged and securely fixed in the support case or the luggage rack box, the electrical system is ready to be used.

#### POWER ON/OFF

In the case of a down tube battery, the system can be switched on by pressing the capacity indicator button on the battery and then pressing the power button on the display.



When the bicycle is not in use, the display and the system turn off automatically after 15 minutes (only when the output current of the battery is less than 100 mA).

For the rack-mounted battery, use the battery's ON/OFF button to switch the system on and then press the power button on the display. To switch off the system, press the OFF button on the battery.

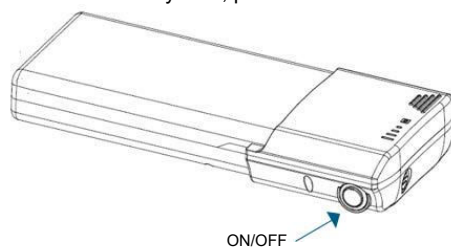

## DOWN TUBE BATTERY RESET

Hold down the button twice for more than 5 seconds (until the first LED lights up); the fifth LED will come on.

Hold down the button once for more than 10 seconds (until the second LED lights up); the fifth LED will go off.

The second and the fourth LEDs will light up. The third LED will flash for approx. 30 seconds.

### BATTERY INDICATOR

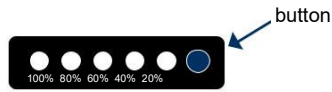

0 – 10%	LED1	flashing
11 – 30%	LED1	on
31 – 50%	LED1 - LED2	on
51 – 70%	LED1 - LED3	on
71 – 90%	LED1 - LED4	on
91 – 100%	LED1 - LED5	on

UNI EN 15194:2012 harmonised standards

Guideline directive(s)

2006/42/EC Machinery Directive

2014/30/EU Electromagnetic Compatibility



# WARRANTY CERTIFICATE

## Buyer details

First name

Surname

Address

Postcode, city

Telephone

Email

## Bicycle details

Model

Colour/Size

Frame Number

Motor Number

Battery Number

Always attach the purchase receipt to this certificate.



Shop stamp

